



WarmUp Track Marathon

Short Option: 1700m

Long Option: 2400m





Way to the Start Marathon and back to the Showground

Only with bicycle! You need to wear a black wristband!



Marathon 8090m



**Start /O1/KM1/CTF1/O2/KM2/CTF2/CTF3/O3/KM3/CTF4/
CTF5/O4/KM4/CTF6/O5/KM5/CTF7/CTF8/O6/KM6/CTF9/
O7/KM7/CTF10/O8/KM8/CTF11/Finish**



Royal Windsor Horse Show 2026

Marathon Times CAIO 4* H4

Section	Distance	Pace	Speed	Minimum Time	Time Allowed	Maximum Time	CTF
	In Harness Inspection						
Warm Up Obstacle	2 min						
Marathon O 1-8	8090 m	→ free after O8 walk or trot	14 km/h	31 min 40 sec	34min 40sec	69 min 20 sec	1 - 11
	In Harness Examination						

Obstacle 1

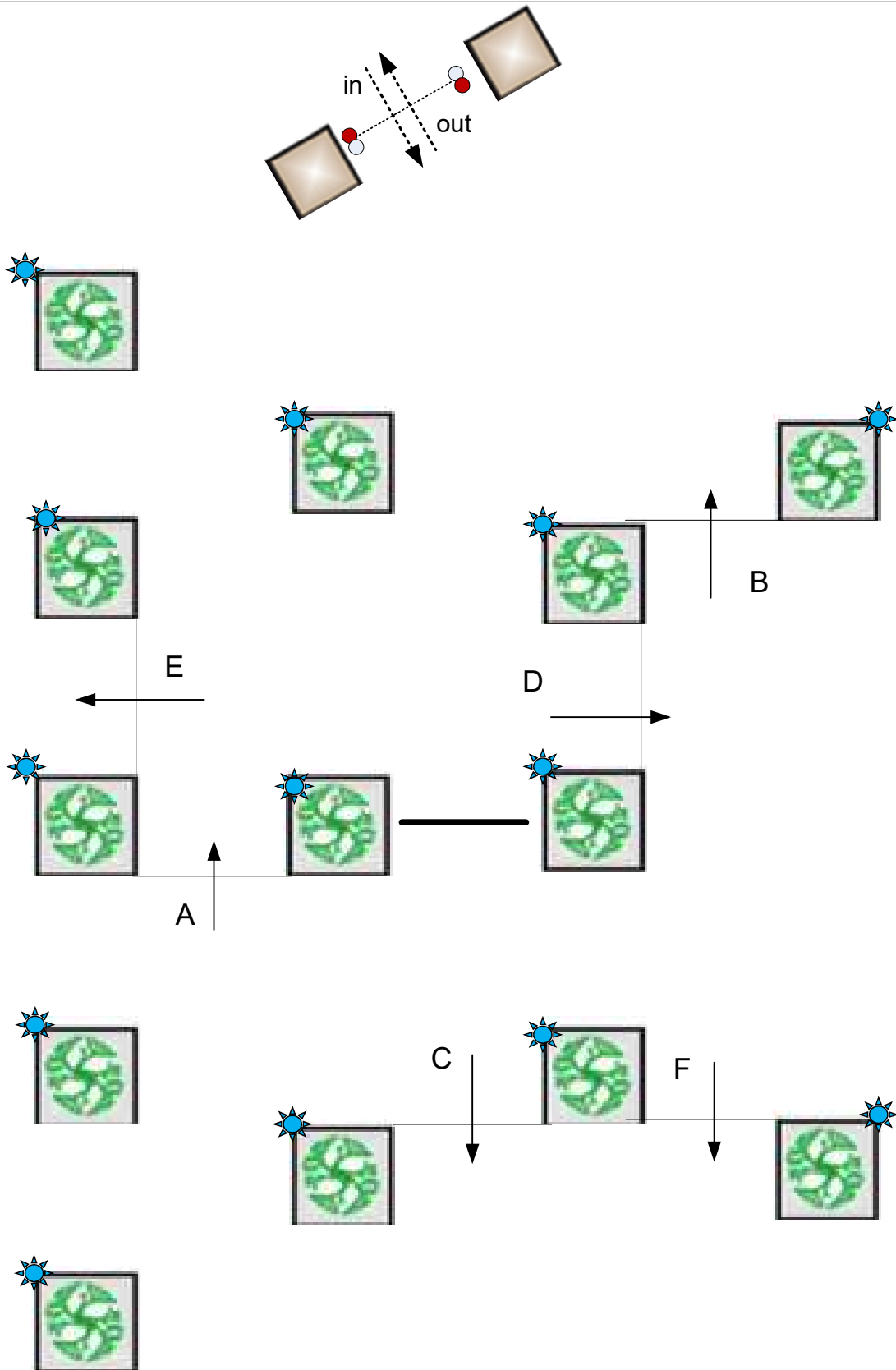

Obstacle 2

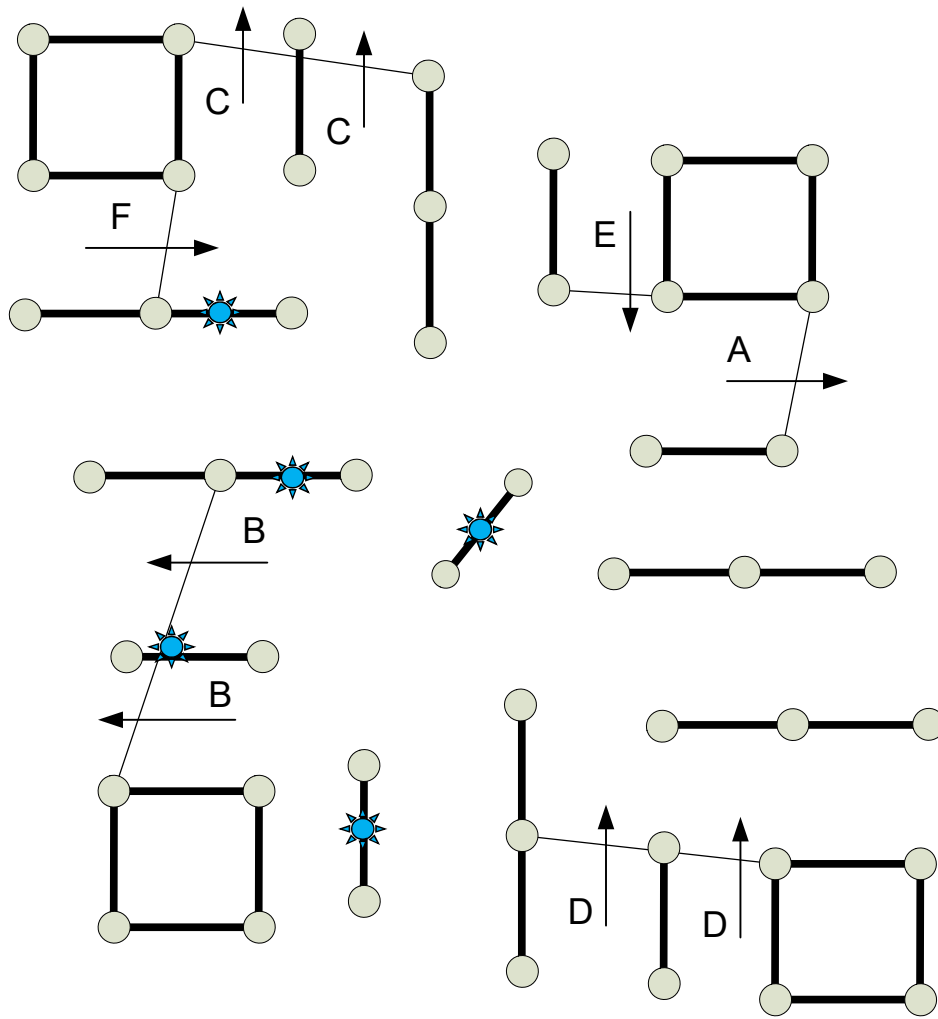

5 Knock Down 

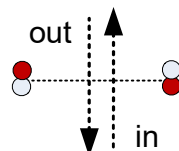

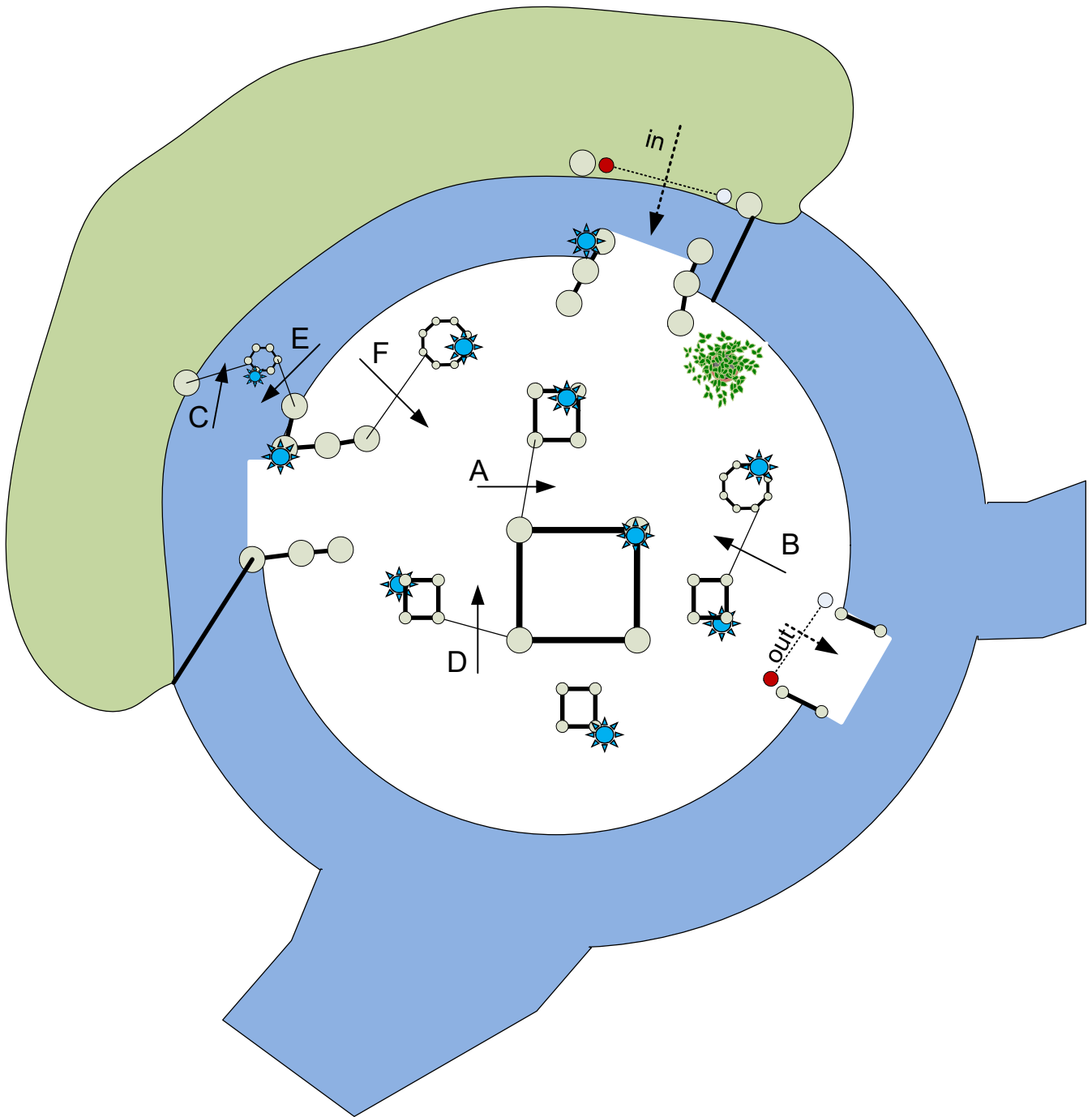

Obstacle 4

The Copper Horse

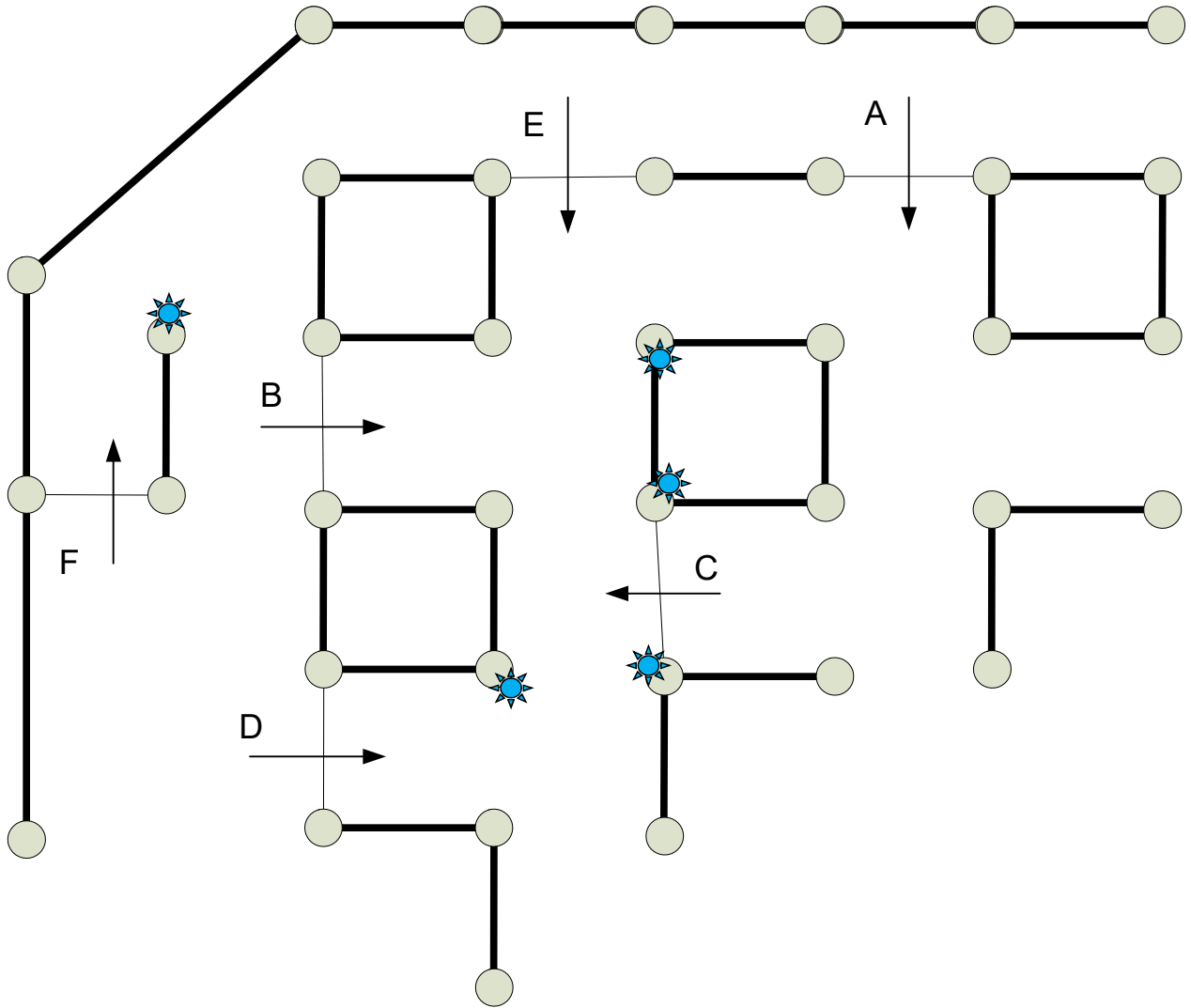

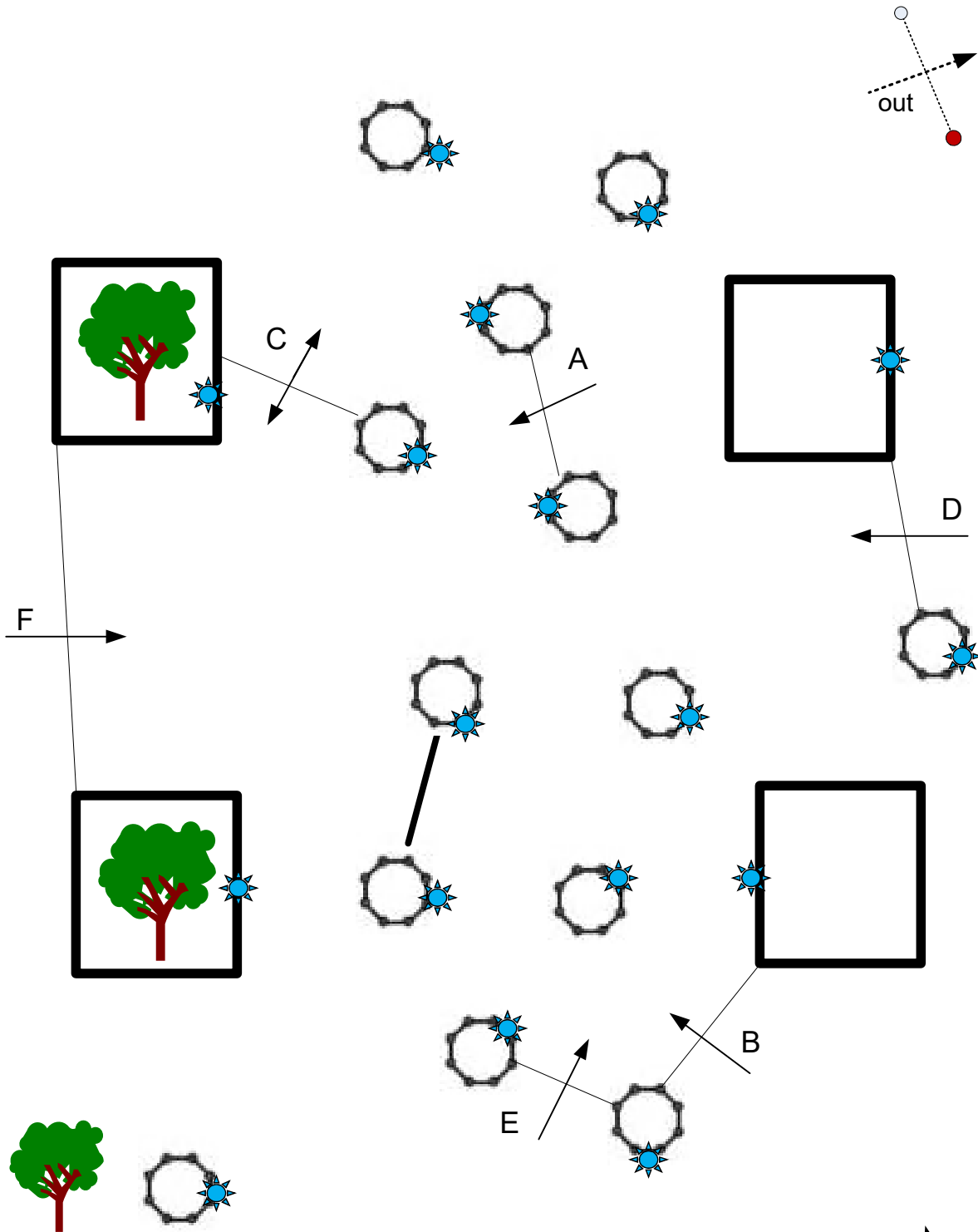

17 Knock Down

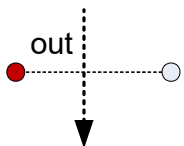
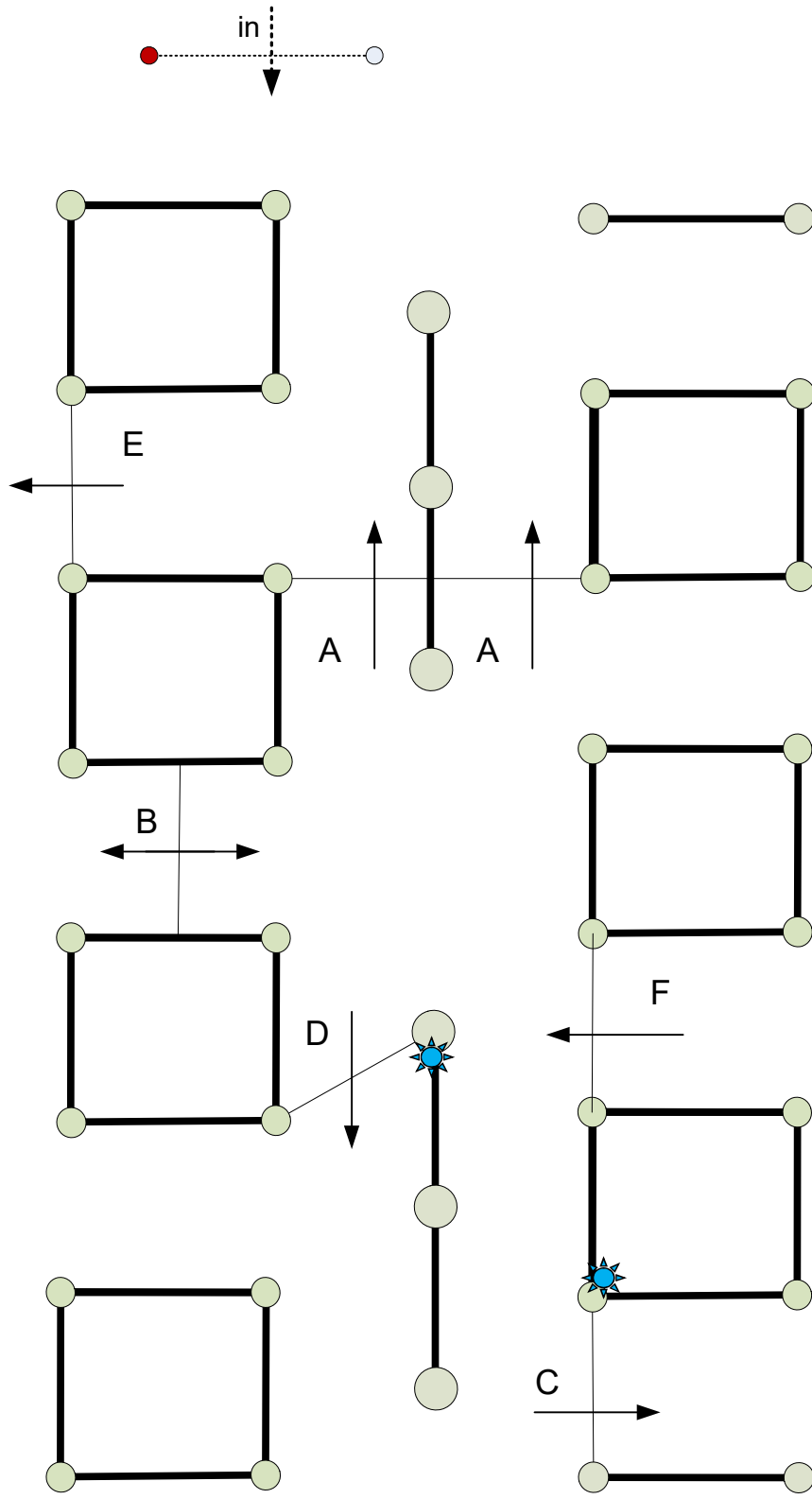

2 Knock Down 



Obstacle 7

« kindly supported
by
Robert Wilkinson »

