



Deutsche Meisterschaften Einspänner Pferde & Ponys + Fahrerinnen und Fahrer mit Handicap



Geländepläne



2022



H1

Labyrinth

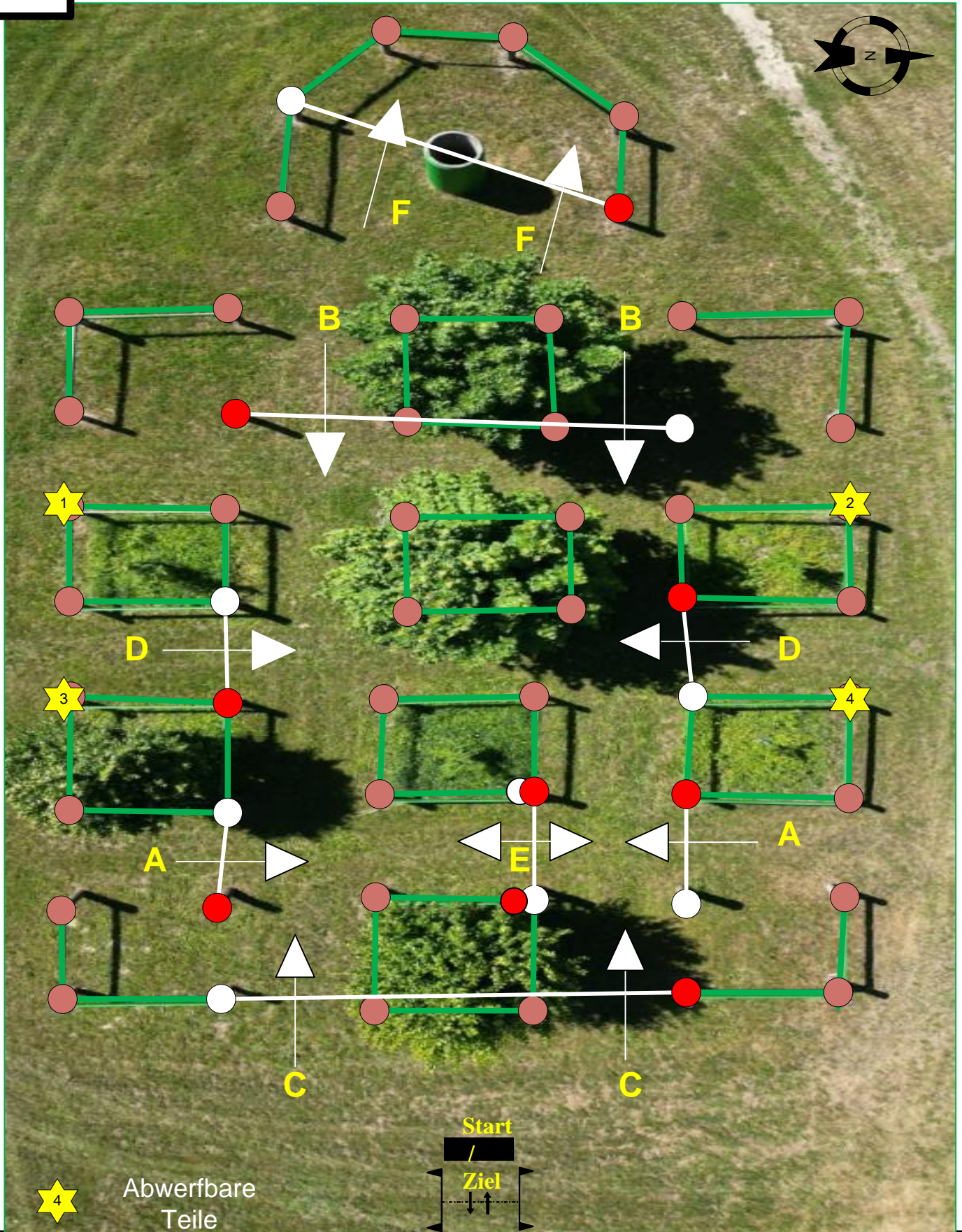

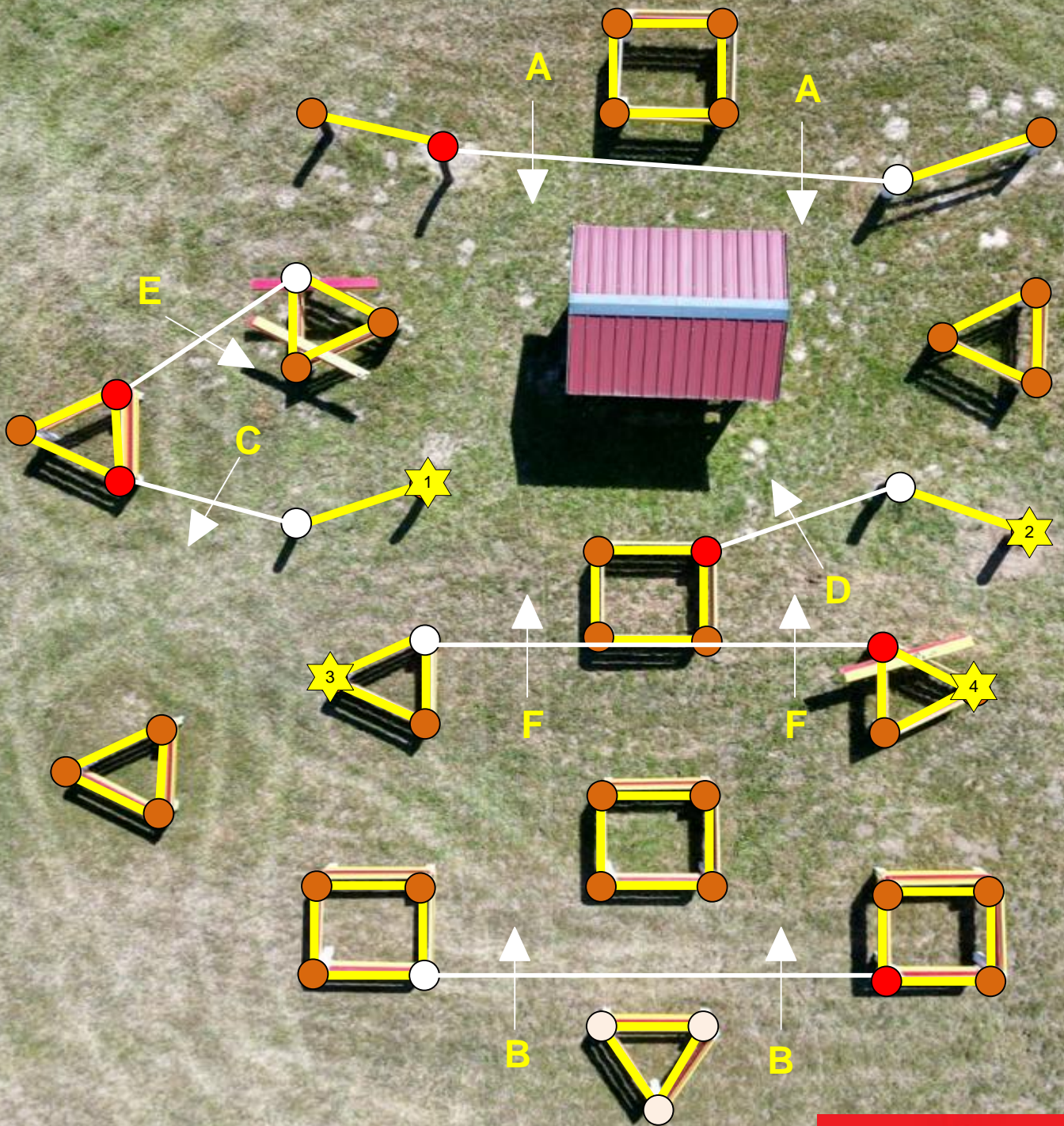

Abwerfbare Teile



Sparkasse
Offenburg/Ortenau

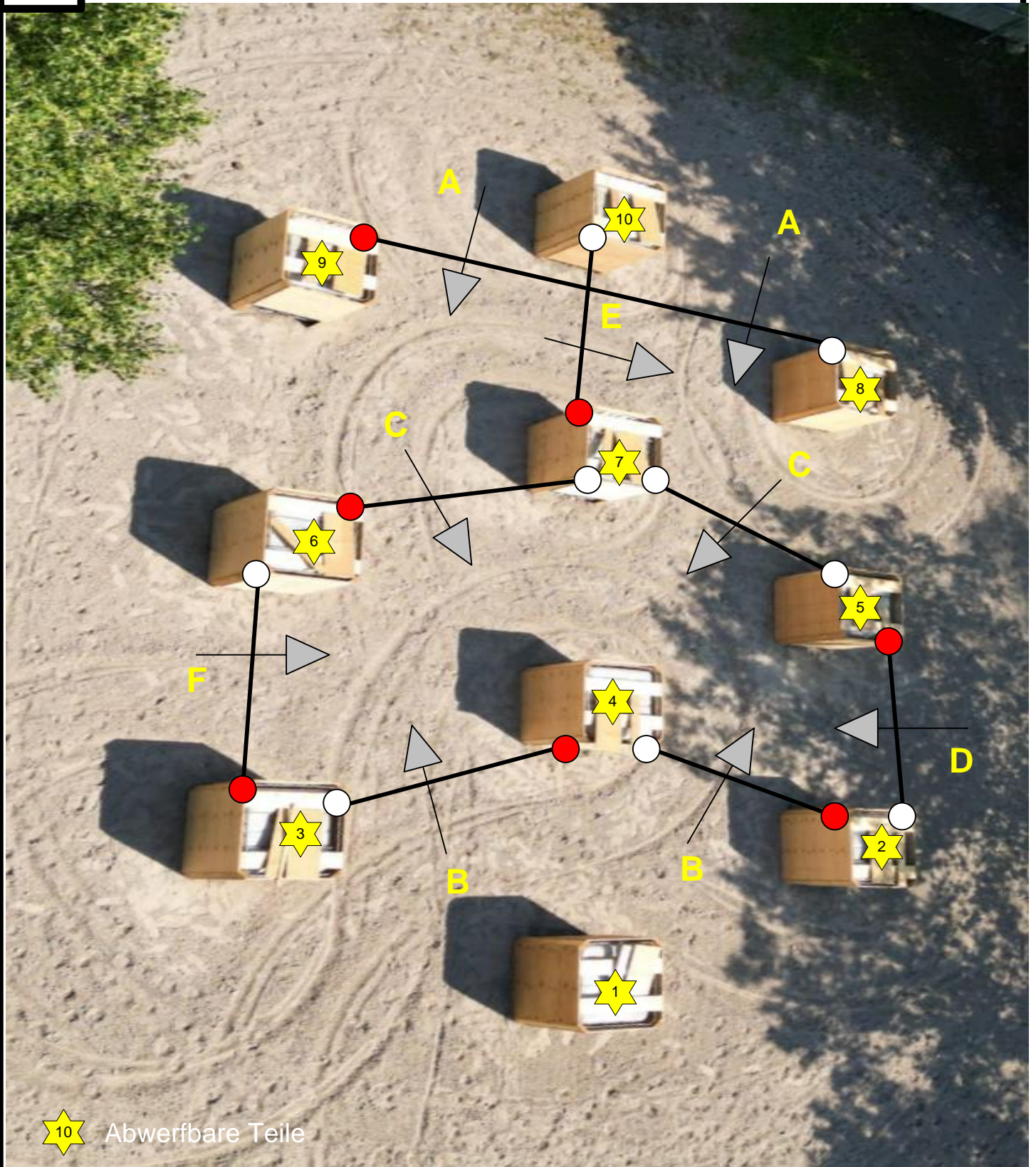

Start ↓
Ziel ↑



★ Abwerfbare Teile

Start / Ziel

Volksbank Lahr

e

H5

WEISS-automotive

Professional Performance in Form und Lack

auto≡motive
weiss

Start/
Ziel

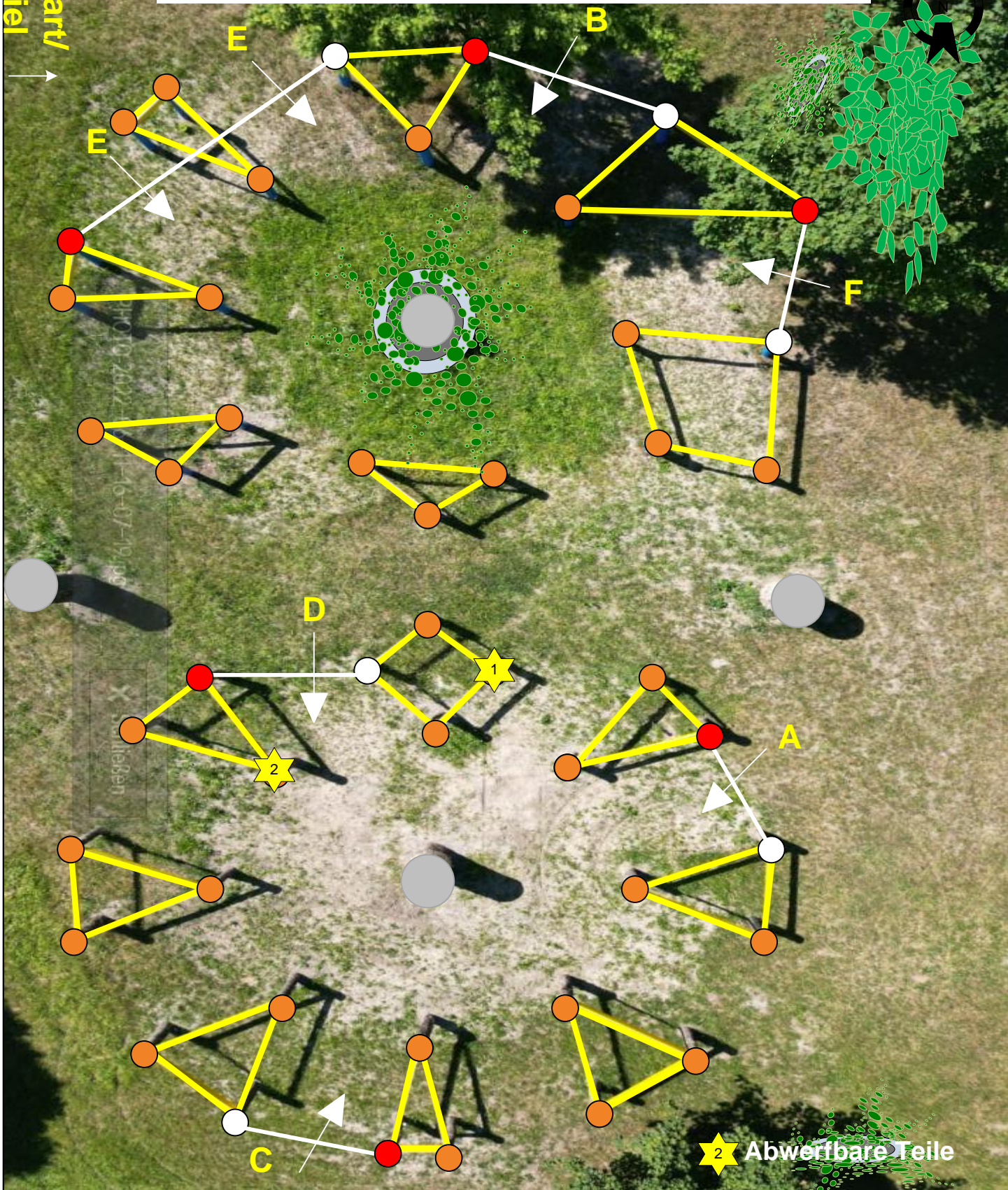

★ Abwerfbare Teile

Reit- u. Fahrverein Ottenheim e.V. 2022



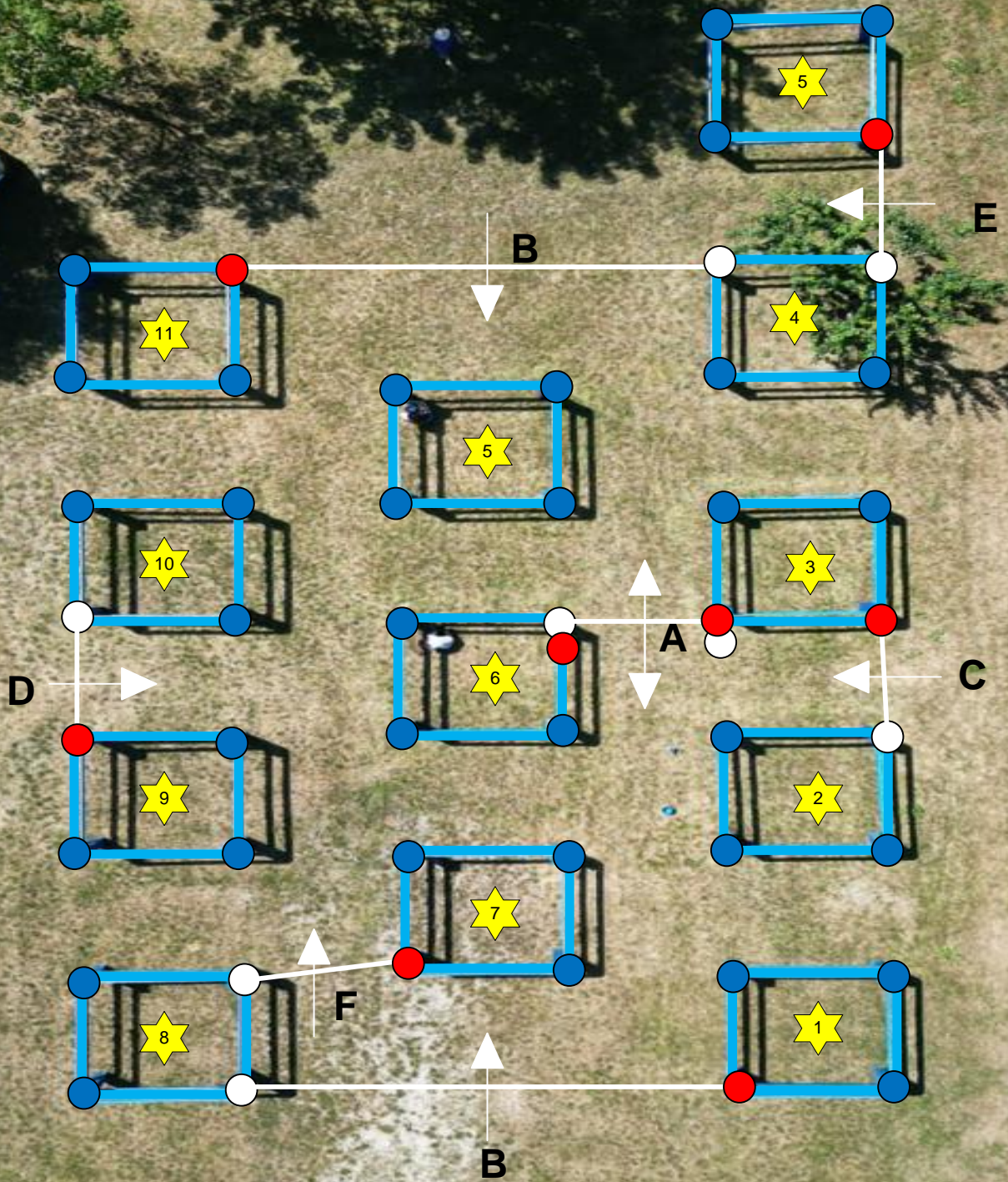
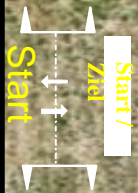

 = 11 abwerfbare Teile



aluminium ■ unser Werkstoff ■ unsere Zukunft

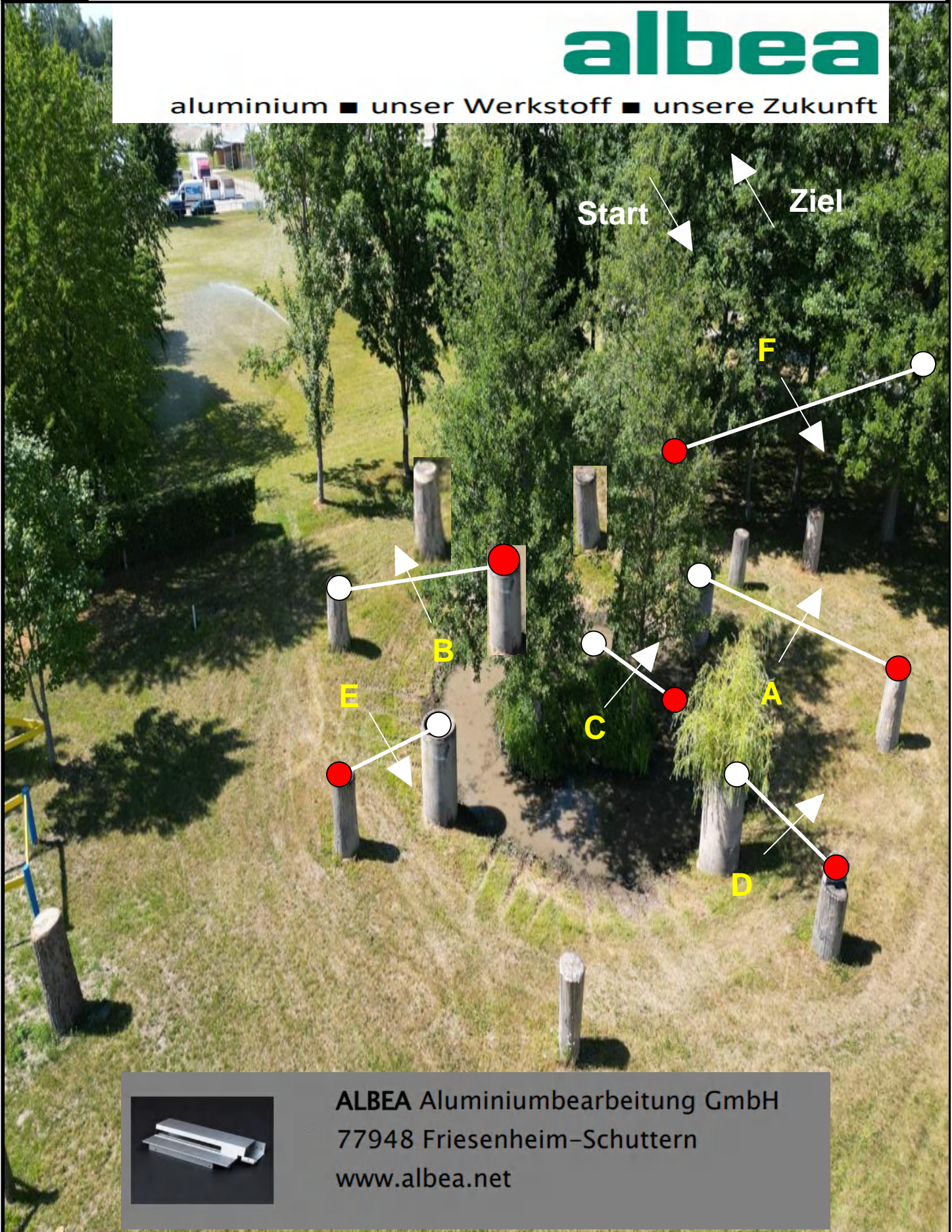

ALBEA Aluminiumbearbeitung GmbH
77948 Friesenheim-Schuttern
www.albea.net

Deutsche Meisterschaften Einspanner Pferde & Ponys + Fahrinnen und Fahrer mit Handicap

Reithalle

Fahrplatz
2
(Hindernisfahren)

Fahrplatz 1
(Dressur)

Ziel-
Hindernis-
strecke

Kl. Reitplatz

Abfahrplatz

Kl. S

Dorfrunde

- T3
- T5
- T7
- T9
- T11
- T13

- T2
- T4
- T6
- T10
- T12
- T14

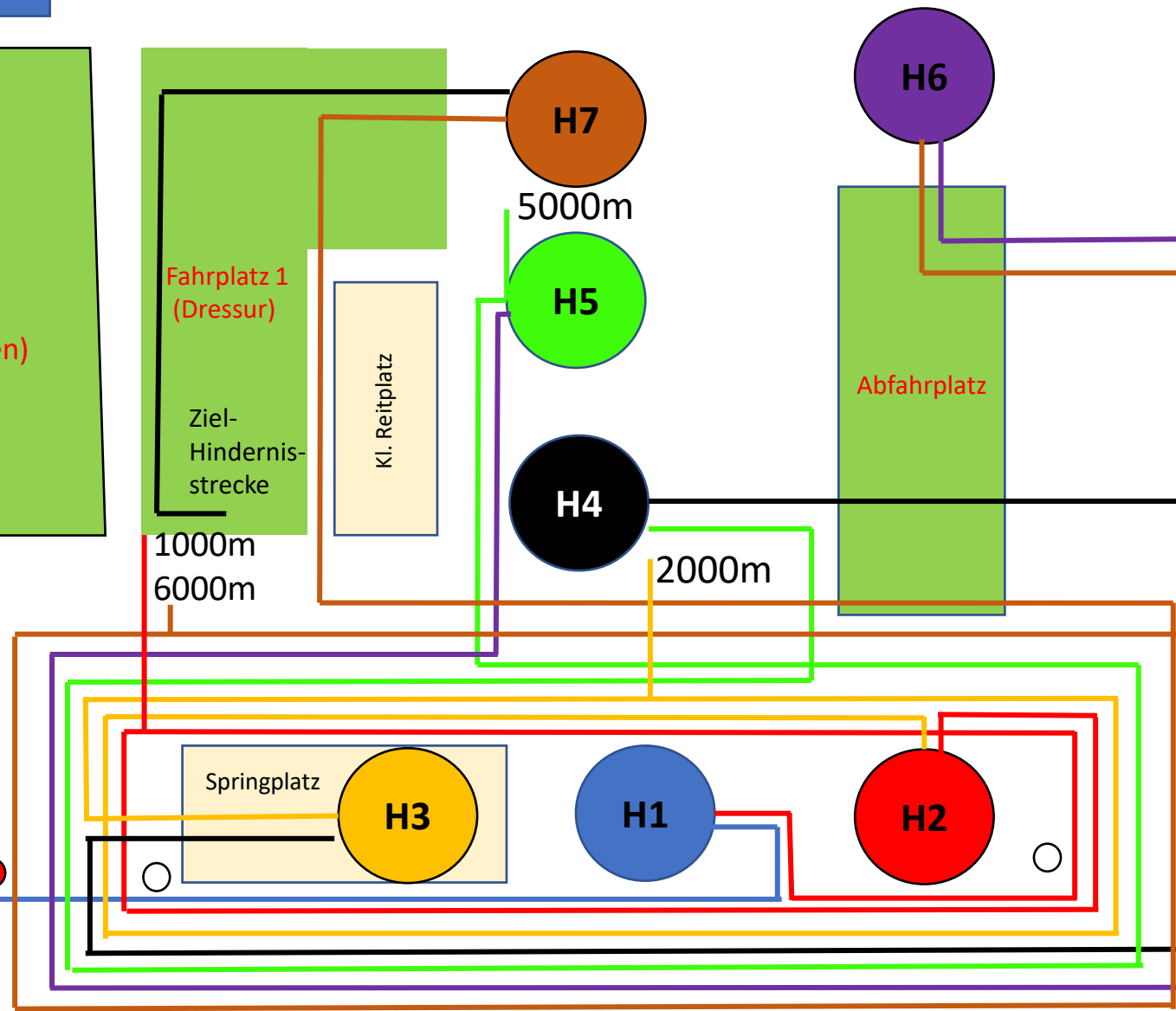

Start-Hindernisstrecke



Start- Aufwärmstrecke, 1000m,
2000m, T1,
3000m,4000m, Ziel
Aufwärmstrecke = 4950m

Vet Check

Ottenheim
Aufwärmstrecke
Klasse S+M

Geländezeiten Ottenheim 2022 Klasse S

<u>Aufwärmstrecke</u>	Tempo Km/h	EZ/ min : sec <u>Streckenlänge(km) x 60</u> Tempo in Km/h	BZ/ min : sec <u>EZ -2 min</u>	HZ/ min : sec <u>EZ + 20%</u>
Pferde 4950 Meter	13	22:50	20:50	27:24
Ponys 4950 Meter	12	24:45	22:45	29:42
<u>Hindernisstrecke</u>	Tempo Km/h	EZ/ min : sec <u>Streckenlänge(km) x 60</u> Tempo in Km/h	BZ/ min : sec <u>EZ -3 min</u>	HZ/ min : sec <u>doppelte EZ</u>
Pferde 7000 Meter	13	32:18	29:18	64:36
Ponys 7000 Meter	12 Warm	35:00	32:00	70:00

Start Aufwärmstrecke- KM1- KM2- T1- KM3- KM4- Ziel

Start Hindernisstrecke – H1- T2- 1000m- T3- T4- H2- T5- T6- 2000m- H3- T7- (Dorfrunde)- 3000m- T8- 4000m- H4- T9- T10- 5000m- H5- T11- T12- H6- 6000m- T13- T14- H7- Ziel

